



## Commander ID300

Integrated Drive for IMfinity® motors  
Decentralized drive system, combining reliability and performances  
0.25 kW to 7.5 kW



**LEROY-SOMER**™

**Nidec**  
All for dreams

# Commander ID300

## All in one drive system solution

Although the transition to 4.0 is under way, the industry is evolving in an increasingly complex and demanding environment.

For this, it is necessary to respond to the main strategic challenges for companies such as quality, risk management, equipment performance and compliance to standards.

Our recognized expertise in drive systems combined with our extensive support organization to users or manufacturers allow us to respond with customized solutions in the demanding fields of Process, Manufacturing and Intralogistics.

Commander ID300 is our new integrated high performance drive solution to control IMfinity® induction motors from 0.25 to 7.5 kW.

The system, with a decentralized configuration offers greater flexibility in machine & plant design.

As no cabinet is required, Commander ID300 is a cost effective and space saving solution. Having no shielded or long cables reduce interference emission and lower power losses.

You benefit from all the functions of a variable speed drive in a simply and compact way.





## The perfect combination between electronics and motors

Based on our most advanced drive, motor, gear and brake technologies, the system integrates the latest generation of electronic components for power and control.

The design and industrialization have been strictly carried out to ensure a very high level of reliability:

- IMfinity®: high efficiency motor with robust housing and proven mechanism
- Unidrive M: world leading drive with open automation systems and functional safety
- FFB: modular, safe and robust brake for dynamic and repetitive braking
- 3000 range gears compact and multi position gear range for maximum adaptability

Whatever the configuration you need (with or without brake, gears), you can rely on a fully optimized system delivered completely assembled with all the selected options and ready to use.

The system, with 2 years warranty and all the worldwide certifications, allows you to benefit from:

- High level of performances
- Advanced control of your machine with onboard PLC and safety features
- Modular system, ready to use

In addition, our powerful industrial organization provides you peace of mind local customer service.

# High level of performances

## Guaranteed motor performance

The performance of the system is ensured with auto calibration and drive setup carried out at the factory.

- Optimized starting torque
- High dynamics on fast transient load
- 180% for 3s motor overload suitable for heavy industrial machinery applications
- Operation at constant torque using flux vector control across the entire speed range
- Maximized throughput with an advanced open loop motor control algorithm

Control Mode	Features
Open loop vector or V/F induction Motor control	Reliable performance and easy configuration Slip compensation Square law V/F mode Dynamic V/F mode
Enhanced open loop Rotor Flux Control (RFC-A)*	High performance speed and torque control through an advanced vector algorithm, utilizing closed loop current control to greatly enhance performance without the need for a feedback device

*\*available soon*

## Enhanced energy efficiency

Commander ID300 allows energy saving and extends system lifetime:

- Higher energy efficiency than the system classification standards IES2 (IEC 50598)
- Low power standby mode for applications where Commander ID300 can sit idle for significant periods
- Square law V/F mode optimized for quadratic loads like pumps and fans to keep motor losses to a minimum
- Dynamic V/F mode to keep energy usage and motor losses to a minimum in low load conditions



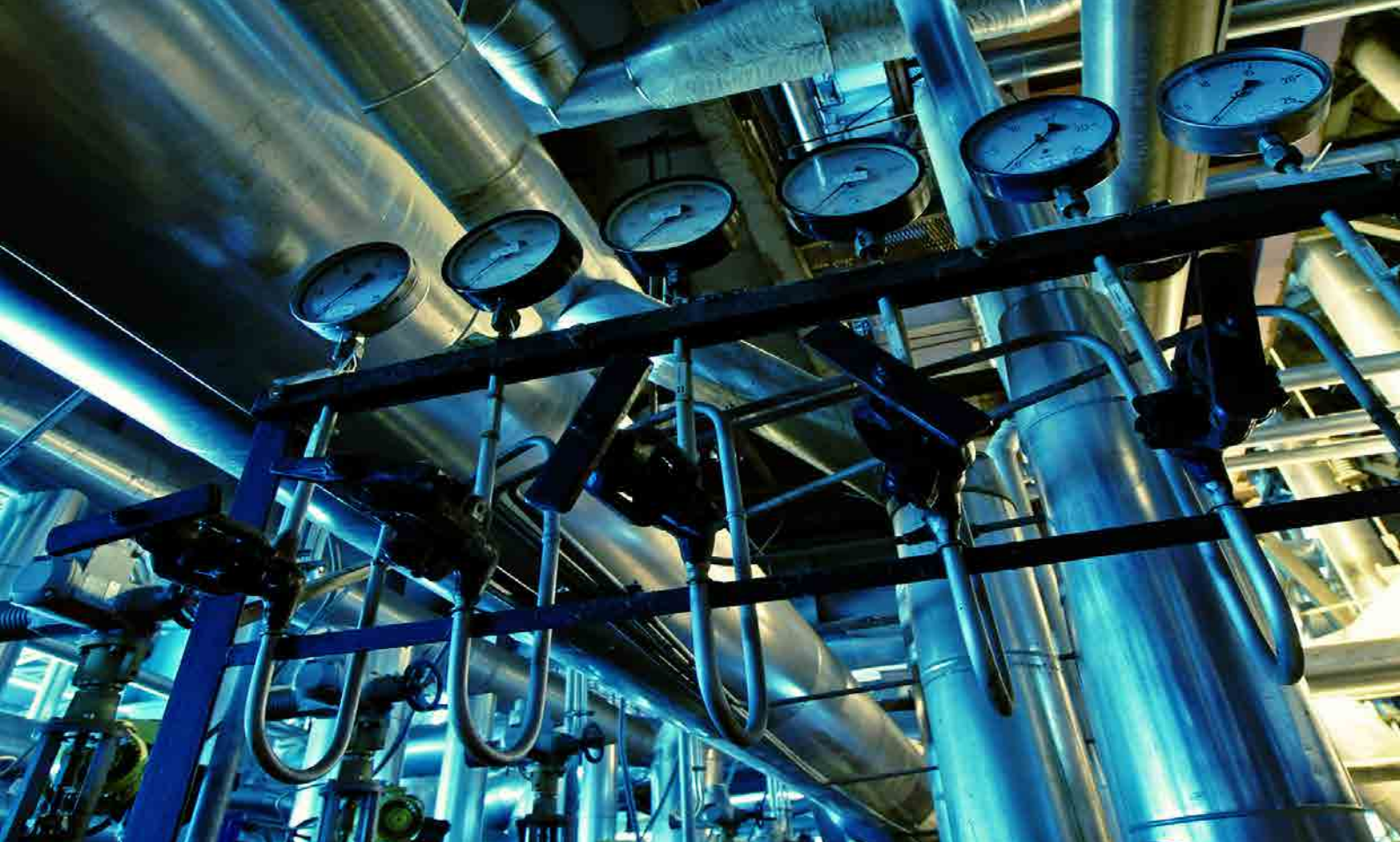

## Robust and reliable system

The system offers guaranteed performance and a protection against the three main causes of failure on the field:

### Protection

- Electronic components encapsulated in resin
- IP55 (65 on request)
- Aluminium drive housing
- Protected and robust IP68 external fan

### Electrical

Wide range of supply voltage to compensate for the variations and disturbances of the different power supply networks allowing to export the machines in complete quietness

### Temperature

The motor and drive associations have been simulated and tested at nominal rating over the speed and torque range. For variable conditions, an additional fan is easily mountable

Each Commander ID300 undergoes at all the important steps of its manufacturing process, various tests to ensure a global and long-lasting reliability of operation (PCBs, drive, motors and final assembly...).

Our expertise of 20 years field feedback in decentralized applications allows us to ensure the continuous improvement of our products.

More importantly, we provide rigorous training to our teams and put in place a technical support organization for the development, commissioning or diagnostic of our customers' machines.

# An advanced control of your machine with onboard PLC and safety features

## Adding value to your application

Commander ID300 provides machine performance optimization:

- Onboard PLC with real-time task to execute a substantial range of sequencing and logic IEC61131-3 programs. No need of additional PLCs
- Onboard pump program to regulate the pressure (constant pressure / variable flow) and the starts of back-up pumps
- Extra Input/output module fitting easily into the drive
- Precise frequency follow-up from an encoder instrumented bearings or inductive sensors (useful for counters or simple positioning)

Commander ID300/302's onboard PLC is programmed using Machine Control Studio software which provides a flexible and intuitive environment for programming.

Programmers have access to a vibrant open-source community for function blocks. Machine Control Studio also supports customers own function block libraries, with on-line monitoring of program variables with user defined watch windows and helps for on-line change of programs, in line with latest PLC practices.

## Simplifying your control systems

The fieldbus communication substantially enhance the way of controlling your machine:

- Facilitate the design of your control architecture
- Intelligent mean and most cost effective option of linking, controlling and monitoring your system
- Increased productivity through precise measurements
- Technological simplicity and familiarity for your application
- Interoperability through open standard fieldbus : Profinet, Ethernet, Ethercat, etc.
- Simplified and more efficient maintenance (remote maintenance of equipment, etc.)





## Caring about safety

Commander ID300 integrates safety features to protect users and machines.

- Commander ID302, a variant of ID300, offers onboard safety functions for compliance with the highest safety standards SIL3 (Safety Integrity Level 3) and PLe (Performance Level e)
- Thermal memory protection to protect the motor against overloads even in case of low power supply (UL approved EN61800-5)
- Full control of the brake sequencing and brake power supply with the brake control option

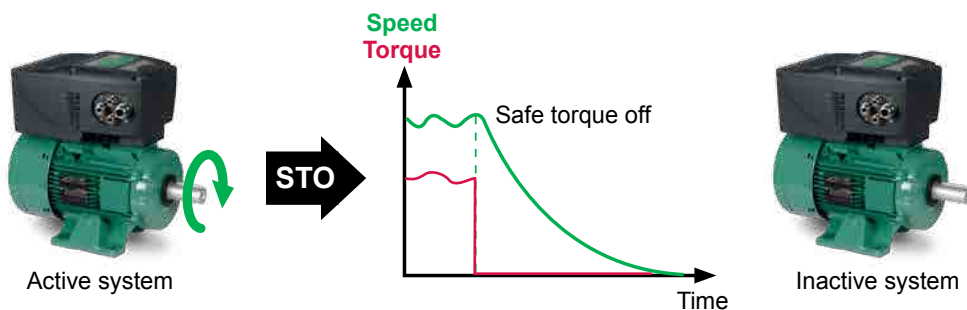

# Modular and ready to use system

## Offering multiple combinations

Our system gives you the opportunity to configure the exact product you need among multiple combinations. Depending on your machine architecture, your process or if you require safety or communication features, you can easily adapt your application with:

- A drive featuring a panel of options according to your needs
- A selection of motors, brakes, gearboxes with dedicated functions and in different variants

Most of the combinations are available in short lead times reducing your stock requirement.

## Ready to use

Through a large panel of features and options, Commander ID300 ensures a quick and smooth operation:

To ease and save time during the installation

- A choice of drive side flanges mounted at the factory
- Click on connectors for fieldbus
- Electrical options connected at the factory

To facilitate system set up, configuration and diagnostics

- 2 ways of set up depending on your application: Intuitive keypad and Connect software with wizards
- LED status display visible even under challenging conditions
- Preset configurations to make control of the machine easier and adapt the drive to your application. By changing only one parameter, the drive automatically processes with the required configuration





Some examples of application for each preset configuration

Segments	Type of applications	Pre-configured setting to be used
<b>Manufacturing</b>	Most of general purpose applications, usually associated with PLC I/Os	Voltage or current frequency reference selected by terminal
	Small winches (frequency reference used to wind/unwind the cable, torque control to maintain cable tension)	Torque control
	Industrial washing machines	Voltage frequency reference or 3 preset references selected by terminals (without brake option)
	Mixers (bakery machines)	Eight preset references selected by terminals
	Mobile machine with local control	Keypad reference and control
<b>Intralogistics</b>	Horizontal and vertical handling, transfer table	Voltage frequency reference and motor PTC with brake option
	Overhead crane (preset references for automatic mode and analog reference for manual mode)	Voltage frequency reference or 3 preset references selected by terminals with brake option
	All types of handling machines	Keypad reference with terminal control
<b>Process</b>	Mobile pumps for fluid transfer (sometimes associated with wireless customer's control), small compressors	Electronic potentiometer
	All kind of motor regulation for pressure, temperature, flow, etc.	PID Control
	Mobile pumps for fluid transfer	Local/Remote
	Main functions required by a pump application with pressure regulation (constant pressure / variable flow)	Pump

# Commander ID300

## Designed to last

### Programming & parameter-setting options

IEC61131-3



Connect, CT scope & Machine control studio



Integrated keypad



Field Keypad RTC

Modbus RJ45 as standard



### Wiring & command

- LED & command side flanges
- Cable entry side flanges



### Brake management

- Brake control option

### Gears



Compabloc, axial



Manubloc, parallel



Orthobloc, bevel



Multibloc, worm & wheel

### Mechanically robust

- Robust cast iron end shields
- Machining of complete stator on mandrel
- Rigorous balancing

### Extended bearing life time

- Properly sized bearing to accept high shaft load
- High quality grease for a long service life

### Approved sealing

- IP55 Sealing system
- Low energy losses shaft sealing

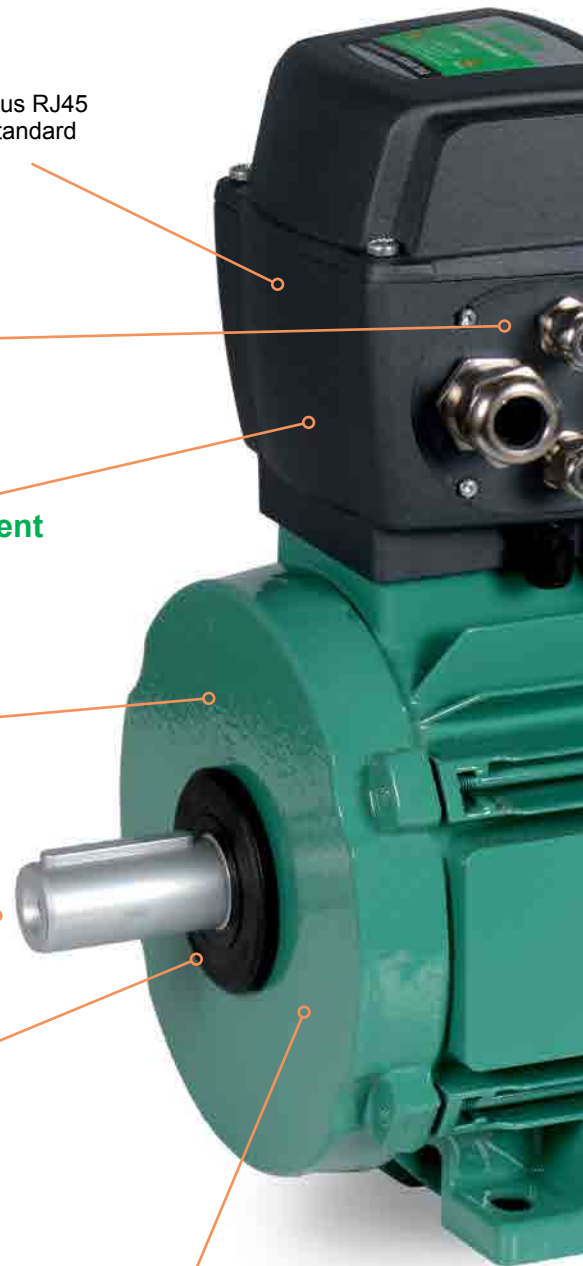

## Communications

SI-EtherCAT



SI-PROFIBUS



SI-Ethernet



SI-DeviceNet



SI-CANopen



SI-PROFINET RT



## I/O expansion

SI-I/O



## Safety

- 2 x STO (ID302 variant)

## Onboard PLC

- Ease of use of the onboard PLC within IEC61131-3 programming environment

## Control modes

- Control of induction motors in open loop flux vector or V/F mode
- RFC (Rotor Flux Control) of induction motors in open loop mode (RFC-A)

## Drive cooling

- Robust fan for performance enhancement

## FFB brake

- Robust and flexible configuration



## Quality commitment

- The motor and drive association has been simulated and tested at nominal rating over the speed and torque range

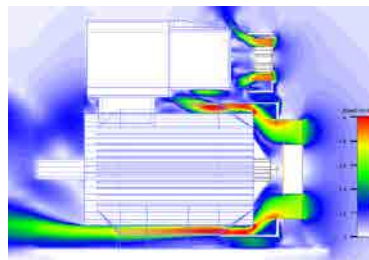

## Electrically robust

- Impregnation varnish without solvent
- Designed with 25K thermal reserve



## Commander ID300 features

Designation	Comments
<b>Construction</b>	
	<ul style="list-style-type: none"> <li>• Environmental protection rating: IP55</li> <li>• Aluminium housing, polyamide plugs</li> <li>• Captive cover screw</li> <li>• Removable screw terminal blocks for power and control wiring</li> <li>• Electronics encapsulated in resin</li> </ul>
<b>Characteristics</b>	
	<ul style="list-style-type: none"> <li>• Mains supply:               <ul style="list-style-type: none"> <li>- 200 V to 230 V <math>\pm 10\%</math>, 1 phase or 3 phases (except Commander ID302 variant)</li> <li>- 380 V to 480 V <math>\pm 10\%</math>, 3 phases</li> <li>- Frequency range: 45 to 66 Hz</li> <li>- 2% negative phase sequence</li> </ul> </li> <li>• Power rating: 0.25 - 0.37 - 0.55 - 0.75 - 0.9 - 1.1 - 1.5 - 1.8 - 2.2 - 3.0 - 4.0 - 5.5 - 7.5 kW</li> <li>• Motor polarity: 2 or 4 poles</li> <li>• Overload: 150% of the full rated output current for 60 seconds or 180% for 3 seconds, 10 times per hour</li> <li>• Starts per hour:               <ul style="list-style-type: none"> <li>- by electronic control: unlimited</li> <li>- by interrupting the AC supply: <math>\leq 20</math> (equally spaced)</li> </ul> </li> <li>• Motor frequency variation range: from 10 to 150 Hz maximum. The range can be different depending on the system (with drive fan, gearmotor, motor polarity)</li> <li>• Maximum output frequency: 150Hz</li> <li>• Efficiency: IES2 level according to EN 61800-9-2. Associated motor can be non IE, IE2 or IE3 depending of the needs and the application</li> </ul>
<b>Environment</b>	
	<ul style="list-style-type: none"> <li>• Storage and transport temperature: -15°C to 55°C, relative humidity 90% maximum</li> <li>• Operating ambient air temperature: -16°C to 40°C, up to 50°C with derating (current derating of 1% per additional Celsius degree from 40°C)</li> <li>• Relative humidity 5 to 95% (non-condensing when operating)</li> <li>• Altitude: &lt; 1,000m ; up to 3,000m with derating. De-rate the maximum output current by 1% per 100 m (330 ft) above 1,000 m (3,300 ft)</li> <li>• Vibrations: meets the requirements of EN 61800-5-1, Table 27 and EN 50178 test 9.4.3.2</li> <li>• EMC: as standard conforms to C3 level and with external filter conforms to C1 level of EN 61800-3 + A1 (2012). Commander ID302 also conforms to EN 61326-3-1 and NF EN 61000-6-7</li> <li>• UL standards: Conforms to UL 61800-5-1_1 (except for associations with brake motors). File number is E211799</li> <li>• RoHS Directive immunity: meets 2011/65/EU directive</li> <li>• Pollution: dry, non-conductive pollution only (pollution degree 2 according to IEC 60664-1)</li> </ul>
<b>Safety</b>	
	<ul style="list-style-type: none"> <li>• Safe torque off inputs included for the Commander ID302 version. Certified by Tüv laboratory and conforms to EN/IEC 61800-5-2. Compliant with SIL3 and PLe level</li> </ul>



## Commander ID300 functionalities

Features	Details
Resolution and sample rate	
Resolution	Preset frequency reference: 0.01 Hz Analog inputs: 11 bits Voltage output: 0.1%
Sample rate	Analog inputs: 4 ms PID: 4 ms
I/O	
Drive capability	2 x Analog / Digital Inputs 1 x Analog / Digital Input 1 x Digital input or output 1x Analog / Digital input or analog output 3 x Digital inputs 1 x Relay
I/O option	4x Digital I/O 3 x Analog inputs (default) / digital inputs 1 x Digital input 2 x Relays
Protection	
Drive thermal protection	When IGBT junction temperature reaches its limit, the drive trips
Motor thermal protection	Motor I <sup>2</sup> t value is continuously calculated. If it exceeds rated motor I <sup>2</sup> t, the drive trips The drive is provided with thermal memory retention
Motor thermistor	Motor thermistor (option) can be managed by the drive in order to get an additional thermal protection
Software detection	Drive detection of undervoltage/overvoltage, phase loss, overload, ground fault short circuit, motor or DC bus overheat, overspeed, etc.
Safety / Security	
Integrated safety function	Dual STO inputs for SIL3 / PLe conformity (Commander ID302 variant only)
User security	User defined security levels: restricted access, read-only parameters
Motor control	
Open loop vector or V/F motor control	Open loop vector control providing the easiest configuration. V/F mode is dedicated to specific motor configurations or applications Square law V/F mode is optimized for quadratic loads like pumps and fans to keep motor losses to a minimum Dynamic V/F mode is intended for applications where power loss should be kept to a minimum under low load conditions. This mode is also used in the case of motor instability (at no load)
Open loop Rotor Flux Control	Vector algorithm utilizing closed loop current control to greatly enhance performance for all induction motor sizes (available soon)
Interfaces	
Fieldbus	Fieldbus options allow the drive to communicate with fieldbus networks: PROFIBUS, CANopen, DeviceNet, Ethernet, EtherCAT, Profinet RT
RS485	RS485 serial port is single insulated and available as standard. An optional serial comms lead can reinforced insulation as defined in IEC60950
Frequency or encoder input	Frequency follow-up is possible from an encoder or frequency input (maximum input frequency: 100 kHz)
Onboard intelligence	
Programmable Logic Control (PLC)	It executes Machine Control Studio (IEC61131-3) programs Memory: 12 kB (user free programming)
Pump program	It provides main functions required by a pump application with pressure regulation (constant pressure / variable flow). It includes a back up pump management which allows the system to start up to 3 additional pumps to maintain a constant pressure on a high flow demand

## Commander ID300 functionalities

Features	Details
Drive software	
Preset references	8 preset references can be set by the user
Catch a spinning motor	If the drive output is inactive after the output bridge is reactivated, it will automatically recalibrate the output frequency to the measured value and reaccelerate the motor up to the reference frequency
Automatic restart after mains loss	On a mains supply loss, the drive will decelerate on a ramp. On return to normal conditions, the motor can be reaccelerated up to its reference speed
S Ramp	A curved part at the start and end of the ramp avoids load swinging
Slip compensation	Slip compensation can be used throughout the speed range of the motor to correct the motor speed and minimise the change of speed with load
Standby mode	Dedicated mode for applications where drives can sit idle for significant periods
Limit switch mode	The motor is stopped without ramps (under DC injection control)
Cost - per kWh electricity	Two parameters accumulate the energy transferred through the drive
DC injection braking	DC injection can be set (injection braking level and time are adjustable)
Drive fan cleaning	Automatic fan cleaning (when the drive fan is fitted) to avoid any dust gathering. The time between fan cleanings can be adjusted
Cooling fan control	If a fan drive is fitted, it can be forced to run at full speed or controlled by the heatsink temperature
Scope mode	Acquire data up to 4 parameters (4 traces)
Skip speeds	3 skip speeds are available to avoid a machine running at critical speeds
Status word	Status word value is the addition of the drive bits envisaged for read-only mode
Trip log	Shows the last ten trips of the drive
PID controller	One general purpose PID controller is provided as standard
Brake control	The association of the brake control preset configuration and the brake control option allow the drive to easily control the FFB brake of the motor. A brake parameter menu is also available for more advanced settings
User preset configurations	User menu can be adjusted to your application by selecting one of the preset configurations
Function blocks	Some functions are included in the software like programmable logic, motorized pot, binary sum, timers, scope, threshold detectors and variable selectors, removing the need for additional devices
Cloning	
Drive Parameter set	Parameter cloning function is available by using Field keypad RTC (function available soon)
Software tools	
Connect	Drive commissioning and monitoring software. Drive parameters can be uploaded, downloaded and compared
Machine Control Studio	Programming software for onboard PLC programs, powered by IEC61131-3 environment
CTScope	Designed to trend/trace parameter values

## ID300 range

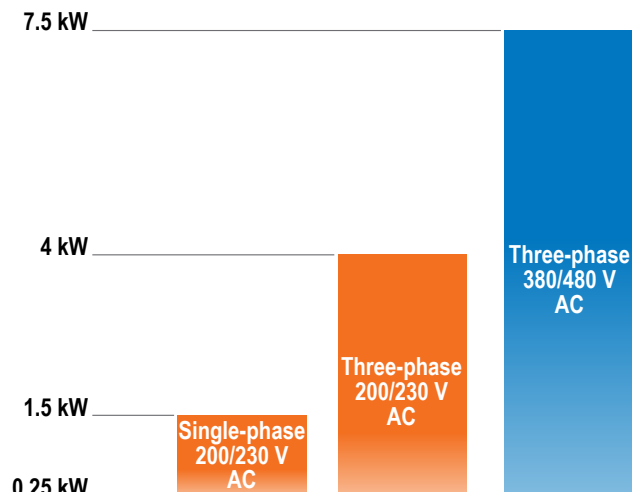

## Commander ID300 options

Commander ID300 integrates many functionalities to meet specific requirements of the applications. To ease the installation and setup, most of the options are factory fitted.

### LED and command side flanges



#### ID-RUN-POT-LED-FLANGE

Drive side flange for local control with 1 potentiometer to easily set the frequency reference, 3 command buttons (Run Forward / Run Reverse / Stop) and 3 LED

#### ID-POT-LED-FLANGE

Drive side flange for local control with 1 potentiometer to easily set the frequency reference and 3 LED

#### ID-LED-FLANGE

Drive side flange with 3 LED

#### ID-BASE-FLANGE (standard)

Blank side flange when remote control is used e.g. with a fieldbus network

• LED informations:

• **Yellow:** not assigned by default, can be set according to the application needs (user setting)

• **Green:** supply OK (permanent) or Drive active (flashing)

• **Red:** Ttrip (permanent) or alarm (flashing)

Trip code can be displayed if a keypad or a PC laptop with Connect software is connected to the drive (RJ45 connection)

• Mounting arrangements: either side of the Commander ID300/302

### Cable entry side flanges



#### ID-3 CABLE RJ45 FLANGE

Side flange with 3 plugs (1xM25 + 1xM20 + 1xM16) for power and control wiring arrangement, and one RJ45 connector to allow direct and quick communication between the drive and Field keypad RTC or Connect software installed on PC/laptop

• Mounting arrangements: on the right seen from the motor drive end only

#### ID-4 CABLE FLANGE (standard)

Side flange with 4 plugs (1xM25 + 1xM20+ 2xM16) for power and control wiring arrangement

• Mounting arrangements: either side of the Commander ID300/302

• Cable gland kits and PC isolated serial communications lead are available to order

### Braking resistors



#### ID-SIZE1-DBR200 and ID-SIZE3-DBR400

Braking resistor to rapidly decelerate a load or to hold back an overhauling load. These dedicated braking resistors have thermal protection included

Size 1 and 2: ID-SIZE1-DBR200 (200 W, 200 Ω)

Size 3: ID-SIZE3-DBR400 (400 W, 100 Ω)

• Mounting arrangements: back side of the drive

### Brake control option



#### ID-SIZE1-Brake Contactor and ID-SIZE3-Brake Contactor

Allows the drive to easily control a motor with FFB brake by using a dedicated drive preset configuration

Size 1 and 2: ID-SIZE1-Brake Contactor

Size 3: ID-SIZE3-Brake Contactor

• Mounting arrangements: factory-fitted inside the drive

## Commander ID300 options

### Drive fans



#### **ID-SIZE1-FAN and ID-SIZE3-FAN**

Fan to improve motor and drive performances

Size 1 and 2: ID-SIZE1-FAN

Size 3: ID- ID-SIZE3-FAN

- Mounting arrangements: back side of the drive.  
For some drive and motor associations, the fan is mounted as standard

### Keypads



#### **ID-SIZE1-Keypad and ID-SIZE3-Keypad**

ID-SIZE1-Keypad for size 1 and 2 drives and ID-SIZE3-Keypad for size 3 drive. The keypad is IP66 and consists of three line plain text, multi-language back-lit LCD display, navigation and command keys for rapid set-up and motor control

- Mounting arrangement: keypad mounted on a terminal cover which replaces the standard one and can easily be fitted by the user (possible keypad rotation of 90° or 180° on the cover)



#### **Field Keypad RTC**

Remote keypad with real time clock. The keypad consists of three line plain text, multi-language LCD display navigation and command keys for rapid set-up and motor control. A battery operated real-time clock allows accurate time stamping of events, aiding diagnostics

- Mounting arrangement: The keypad can be easily connected to the drive by the user, using the RJ45 connector of ID-3 CABLE RJ45 FLANGE option. Parameter cloning function available soon

### Fieldbus and I/O expansion



#### **PROFIBUS, CANopen, DeviceNet, Profinet RT, Ethernet or EtherCAT module**

Size 1 and 2 drives: Those options are module boxes ref ID-SIZE1 + module name

Size 3 drives: they are modules to be integrated SI-+module name for instance SI-PROFIBUS

They allow communication with a fieldbus network (Profibus, CANopen, DeviceNet, Profinet RT, Ethernet or EtherCAT)

2 x Fast M12 connectors for easy connection

**Inputs/outputs:** this option increases the I/O capability of the drive (digital I/O and analog inputs, relays)

Size 1 and 2 drives: this option is a module box ref ID-SIZE1-I/O

Size 3 drives: this option is a module to be integrated ref SI-I/O

- Mounting arrangement: fieldbus or I/O modules are user fitted. For the module box, it can easily be fitted by the user, replacing the standard cover



### EMC filter



#### **ID-size1-EMC filter-LV-LL, ID-size1-EMC filter-HV-LL, ID-size3-EMC filter-HV-LL**

- Commander ID300 is intended for use in the second environment according to IEC 61800-3:2004 and EN 61800-3:2004+A1:2012 standards. For better emission compliance, the external filter should be added e.g in residential environment

- Mounting arrangements

Size 1: can easily be fitted by the user on the side of the drive

Size 3: can easily be fitted by the user inside the drive





**Nidec**  
**LEROY-SOMER**

**CAUTION**  
Risk of electric shock  
Power down unit  
10 minutes before removing cover

10min

**Commander ID300/302**

# Commander ID300 system

## Selection of Commander ID300 system, with or without brake

As the motor and drive have been specifically designed for use in combination, the highest levels of performance are offered to drive the machine.

Leroy-Somer offers multiple system configurations with three different efficiency levels: Non-IE (non-rated), IE2 and IE3. You have the possibility to add a brake and/or a gearbox.

Before selecting, define the following:

- type of system (motor, geared motor with or without brake),
- motor polarity,
- efficiency level,
- power of the motor and drive (Pn expressed in kW from 0.25 to 7.5),
- mains voltage (400V three phase, 230V three phase or 230V single phase)
- fixing form (feet, smooth or tapped hole flanges)

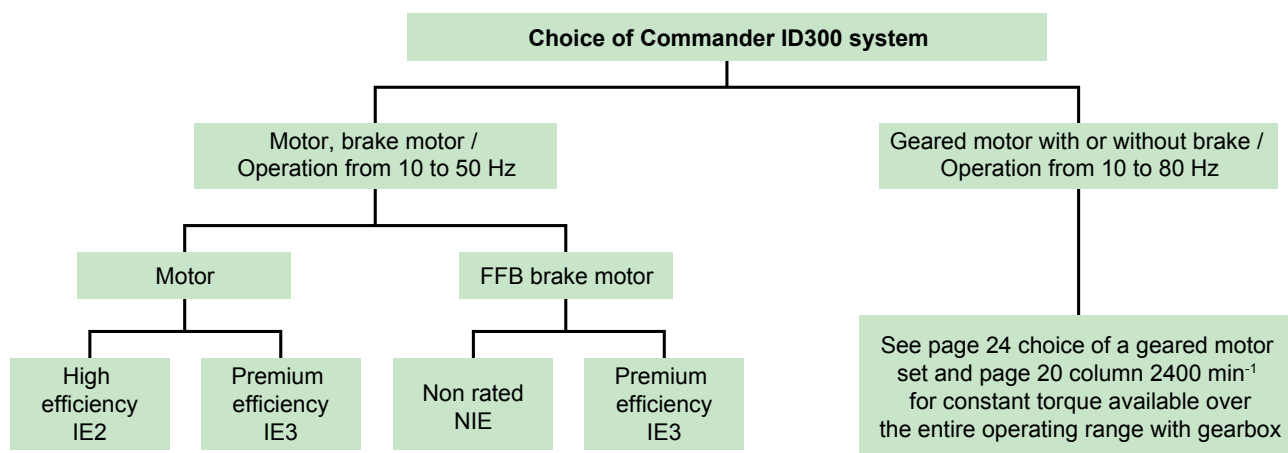

**LSES motor**  
IE2 or IE3  
0.25 to 7.5 kW



**FFB Brake Motor**  
NIE or IE3  
0.25 to 7.5 kW



**Geared motor with or without brake**  
NIE, IE2 or IE3  
0.25 to 7.5 kW

## Typical designation of a Commander ID300 system with a FFB brake

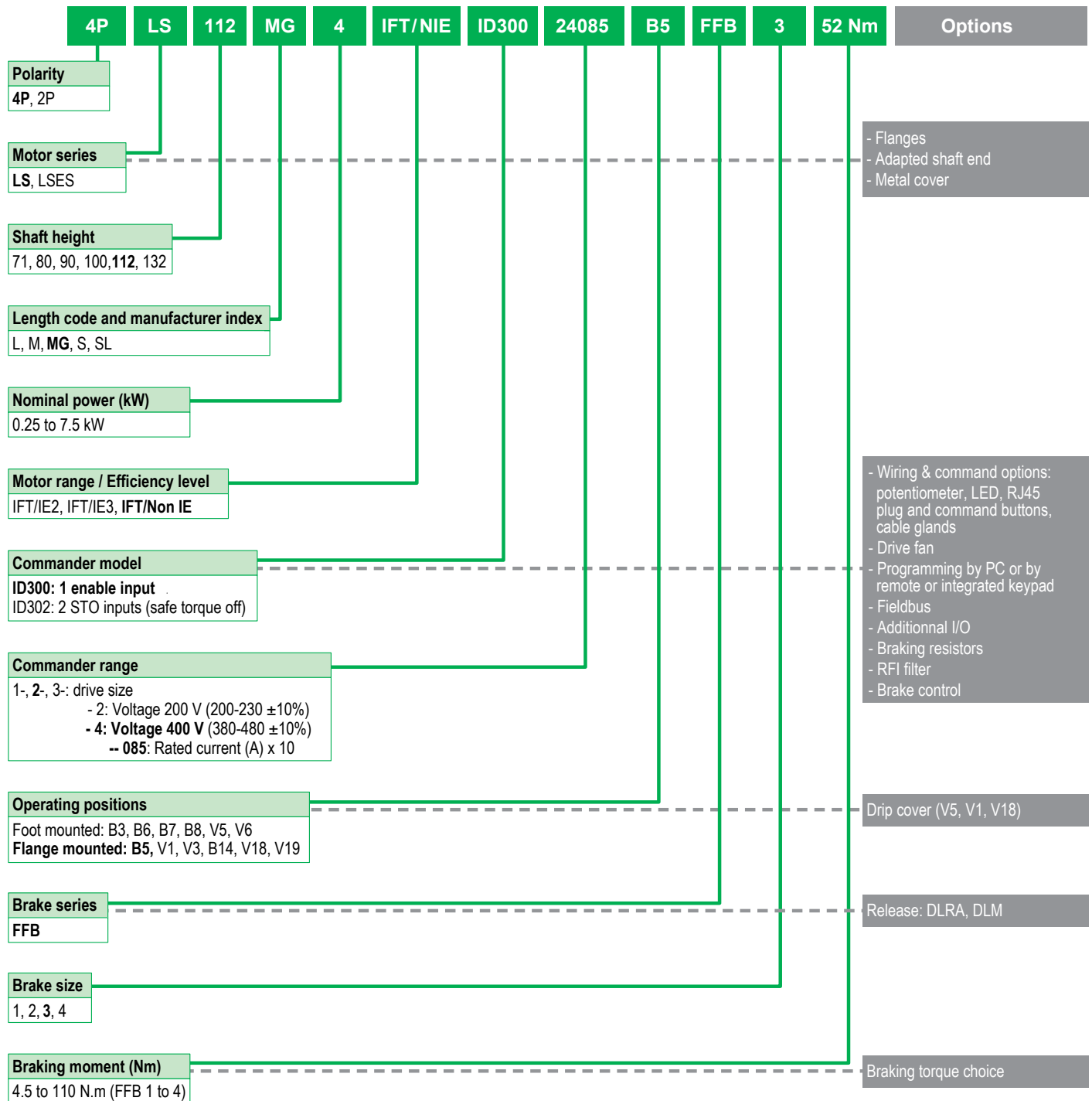

## Selection table of Commander ID300 system with or without FFB brake

### 4-pole motor - IFT/IE2 - LSES - 230/400 V - IP55

Motor type	Rated power P <sub>n</sub> kW	COMMANDER type		Torque available (Nm) at speeds (min <sup>-1</sup> )						Starting torque M <sub>s</sub> Nm	Motor moment of inertia J kg.m <sup>2</sup>	Brake type	COMMANDER type ID300-ID302 400V 3 ph	Braking torque <sup>1</sup> M <sub>i</sub> Nm	FFB brake motor moment of inertia J kg.m <sup>2</sup>
		ID300 230V 1ph	ID300 230V 3ph	ID300-ID302 400V 3 ph	300 Nm	500 Nm	750 Nm	1500 Nm	2400 Nm						
LS 80 LG	0.75	12030	14021	3.2	4.2	4.6	5	3.1	9	0.00265	-	-	-	-	
LS 80 LG	0.9	22035	14025	3.9	5.1	5.5	6	3.7	10.8	0.00316	-	-	-	-	
LS 90 SL	1.1	22052	14030	4.8	6.3	6.8	7.4	4.6	13.3	0.00336	-	-	-	-	
LS 90 L	1.5	22057*	14033	6.5	8.4	9.2	9.9	6.2	17.8	0.00418	-	-	-	-	
LS 90 LU	1.8	-	24042	7.8	10.2	11.0	12	7.6	21.6	0.00450	-	-	-	-	
LS 100 L	2.2	-	32087*	24050	9.5	12.4	13.4	14.6	9.0	0.00567	-	-	-	-	
LS 100 LR	3	-	32120*	24070*	15.9	19.8	19.8	19.8	12.3	0.00677	-	-	-	-	
LS 112 MU	4	-	32155*	24085*	20.9	26.1	26.2	26.1	16.2	0.01312	-	-	-	-	
LS 132 SU	5.5	-	-	34119*	28.7	35.9	35.9	35.9	22.2	0.01611	-	-	-	-	
LS 132 M	7.5	-	-	34155*	39.7	49.4	49.4	49.5	30.7	0.02286	-	-	-	-	

\*Drive fan included

Torque available over the entire operating range when fitted to gearbox

### 4-pole motor or brake motor - IFT/NIE - LS - 230/400 V - IP55

Motor type	Rated power P <sub>n</sub> kW	COMMANDER type		Torque available (Nm) at speeds (min <sup>-1</sup> )						Starting torque M <sub>s</sub> Nm	Motor moment of inertia J kg.m <sup>2</sup>	Brake type	COMMANDER type ID300-ID302 400V 3 ph	Braking torque <sup>1</sup> M <sub>i</sub> Nm	FFB brake motor moment of inertia J kg.m <sup>2</sup>
		ID300 230V 1ph	ID300 230V 3ph	ID300-ID302 400V 3 ph	300 Nm	500 Nm	750 Nm	1500 Nm	2400 Nm						
LS 71 M	0.25	12017	14012	0.9	1.4	1.6	1.7	0.9	3.1	-	FFB1	14012	4.5	0.00094	
LS 71 M	0.37	12024	14015	1.4	2.1	2.3	2.5	1.4	4.5	-	FFB1	14015	4.5	0.00111	
LS 71 L	0.55	12030	14018	2.1	3.2	3.5	3.8	2.1	6.8	-	FFB1	14018	6	0.00136	
LS 80 L	0.75	-	-	4	4.5	4.8	5.1	3.2	9.2	-	FFB1	14021*	12	0.00190	
LS 80 L	0.9	-	-	5.1	5.4	5.8	6.1	3.8	11	-	FFB1	14025*	12	0.00266	
LS 90 SL	1.1	-	-	6.2	6.6	7	7.4	4.6	13.3	-	FFB2	14030*	19	0.00353	
LS 90 L	1.5	-	-	8.5	9.5	9.8	10	6.2	18	-	FFB2	14033*	19	0.00425	
LS 90 L	1.8	-	-	10.8	11.8	11.9	12	7.5	21.6	-	FFB2	24042*	26	0.00469	
LS 100 L	2.2	-	-	12.4	13.9	14.3	14.6	9.1	26.3	-	FFB2	24050*	26	0.00518	
LS 100 L	3	-	-	17	19	19.5	20	12.5	36	-	FFB3	24070*	52	0.00655	
LS 112 MG	4	-	-	24	27	26.7	26.7	16.7	48.1	-	FFB3	24085*	52	0.01240	
LS 132 S	5.5	-	-	32.4	35.9	36	36	22.5	64.8	-	FFB3	34119*	67	0.0154	
LS 132 M	7.5	-	-	34.0	37.8	39.9	44.5	30.8	80.1	-	FFB4	34155*	110	0.0252	

<sup>1</sup>Values given for information only; for standards-related restrictions, please consult us. \*Drive fan included

Torque available over the entire operating range when fitted to gearbox

### 4-pole motor or brake motor - IFT/IE3 - LSES - 230/400 V - IP55

Motor type	Rated power P <sub>n</sub> kW	COMMANDER type		Torque available (Nm) at speeds (min <sup>-1</sup> )						Starting torque M <sub>s</sub> Nm	Motor moment of inertia J kg.m <sup>2</sup>	Brake type	COMMANDER type ID300-ID302 400V 3 ph	Braking torque <sup>1</sup> M <sub>i</sub> Nm	FFB brake motor moment of inertia J kg.m <sup>2</sup>
		ID300 230V 1ph	ID300 230V 3ph	ID300-ID302 400V 3 ph	300 Nm	500 Nm	750 Nm	1500 Nm	2400 Nm						
LS 80 LG	0.75	12030	14021	3.3	4.3	4.6	5.0	3.1	9	0.00335	FFB1	14021	12	0.00361	
LS 80 LG	0.90	22035	14025	3.9	5.1	5.5	6.0	3.7	10.8	0.00381	FFB1	14025	12	0.00407	
LS 90 SL	1.10	22052	14030	4.7	6.2	6.7	7.2	4.5	13	0.00418	FFB2	14030	19	0.00506	
LS 90 LU	1.50	22057*	14033	6.4	8.3	9.1	9.9	6.1	17.8	0.00524	FFB2	14033	19	0.00612	
LS 100 L	1.80	-	32075*	24042	7.9	10	11	12	7.6	0.00561	FFB2	24042	26	0.00649	
LS 100 LR	2.20	-	32087*	24050	9.5	12.2	13.3	14.5	9	0.00676	FFB2	24050	26	0.00764	
LS 100 LG	3.00	-	32120*	24070*	15.6	19.5	19.5	19.5	12.1	0.01152	FFB3	24070*	52	0.01239	
LS 112 MU	4.00	-	32155*	24085*	21.1	26.2	26.2	26.2	16.2	0.01312	FFB3	24085*	52	0.01399	
LS 132 SM	5.5	-	-	34119*	28.7	35.8	35.8	35.8	22.2	0.02286	FFB4	34119*	67	0.02889	
LS 132 MU	7.5	-	-	34155*	39	49	49	49.2	30.5	0.02965	FFB4	34155*	110	0.03559	

<sup>1</sup>Values given for information only; for standards-related restrictions, please consult us. \*Drive fan included

Torque available over the entire operating range when fitted to gearbox

### 2-pole motor - IFT/IE3 - LSES - 230/400 V - IP55

Motor type	Rated power P <sub>n</sub> kW	COMMANDER type		Torque available (Nm) at speeds (min <sup>-1</sup> )						Starting torque M <sub>s</sub> Nm	Motor moment of inertia J kg.m <sup>2</sup>	Brake type	COMMANDER type ID300-ID302 400V 3 ph	Braking torque <sup>1</sup> M <sub>i</sub> Nm	FFB brake motor moment of inertia J kg.m <sup>2</sup>
		ID300 230V 1ph	ID300 230V 3ph	ID300-ID302 400V 3 ph	600 Nm	1000 Nm	1500 Nm	3000 Nm	4800 Nm						
LS 71 M	0.37	12024	14015	-	-	-	1.26	0.8	2.3	0.00035	-	-	-	-	
LS 71 L	0.55	12030	14018	-	-	-	2	1	3.4	0.00045	-	-	-	-	
LS 80 L	0.75	12030	14021	1.6	2.1	2.3	2.5	1.5	4.5	0.00095	-	-	-	-	
LS 80 LG	1.1	22052	14030	2.4	3.1	3.4	3.7	2.3	6.7	0.00223	-	-	-	-	
LS 90 SL	1.5	22057	14033	3.2	4.2	4.6	5	3.1	9	0.00223	-	-	-	-	
LS 90 L	1.8	-	24042	3.9	5.1	5.6	6	3.8	10.8	0.00292	-	-	-	-	
LS 90 LU	2.2	-	24050	4.7	6.2	6.7	7.3	4.5	13.1	0.00292	-	-	-	-	
LS 100 L	3	-	32120*	24070*	8.1	10.1	10.1	10.1	6.3	0.00364	-	-	-	-	
LS 112 MG	4	-	32155*	24085*	10.6	13.2	13.2	13.2	8.2	0.00941	-	-	-	-	
LS 132 S	5.5	-	-	34119*	14.3	17.8	17.8	17.8	11.1	0.01116	-	-	-	-	
LS 132 SM	7.5	-	-	34155*	19.4	24.3	24.3	24.3	15.1	0.01102	-	-	-	-	

\*Drive fan included





## Dimensions of Commander ID300 system with or without FFB brake

IM B3 Feet form (IM 1001)

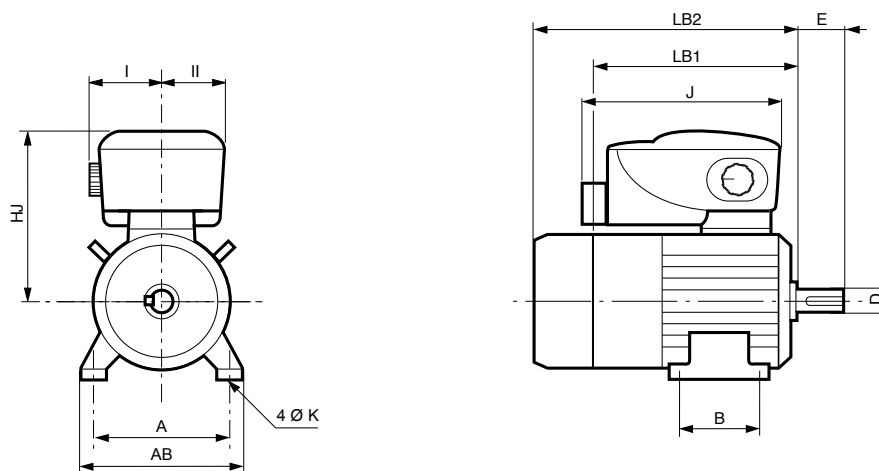
Dimensions in millimeters



Motor type	Feet Form											Output shaft				
	A	AB	B	HJ	4xK	I <sup>(1)</sup>	II	Jmax <sup>(2)</sup>	Motor LB1	 kg <sup>(2)</sup>	Brake type	Jmax <sup>(2)</sup>	Brake mot LB2	 kg <sup>(2)</sup>	D	E
LS 71 M	112	126	90	194	7	94	75	217	186	11.5	FFB1	277	286	14.5	14j6	30
LS 71 L	112	126	90	194	7	94	75	217	194	12.5	FFB1	277	296	15.5	14j6	30
LS 80 L	125	157	100	235	9	94	75	217	-	-	FFB1	277	312	18.1	19j6	40
LSES 80 LG	125	157	100	245	9	94	75	277	245	15.1	FFB1	277	389	22.2	19j6	40
LS 90 SL	140	172	125	245	10	94	75	277	-	-	FFB1, 2	277	389	22.4	19j6	40
LS 90 L	140	172	125	245	10	94	75	277	-	-	FFB2	277	389	29.1	24j6	50
LSES 90 SL	140	172	125	245	10	94	75	277	245	20.4	FFB1, 2	277	389	26.6	24j6	50
LSES 90 L	140	172	125	312.2	10	94	75	277	245	18	-	-	-	-	24j6	50
LSES 90 LU	140	172	125	312.2	10	94	75	277	276	24.6	FFB2	390	389	30.8	24j6	50
LS 100 L	160	196	140	317.2	12	141	115	336	-	-	FFB2, 3	390	437	37.2	28j6	60
LSES 100 L	160	196	140	317.2	12	141	115	336	290	30.7	FFB2	390	437	36.9	28j6	60
LSES 100 LR	160	196	140	317.2	12	141	115	336	309	33.9	FFB2	390	437	40.1	28j6	60
LSES 100 LG	160	196	140	326.2	12	141	115	390	315	30.6	FFB2, 3	390	423	45.7	28j6	60
LS 112 MG	190	220	140	326.2	12	141	115	390	-	-	FFB3	390	448	37.7	28j6	60
LSES 112 MU	190	220	140	326.2	12	141	115	390	332	31.1	FFB3	390	448	49.1	28j6	60
LS 132 S	216	250	140	349.2	12	141	115	390	-	-	FFB3	390	490	52.7	38k6	80
LSES 132 SU	216	250	140	349.2	12	141	115	390	383	46.1	-	-	-	-	38k6	80
LSES 132 SM	216	250	140	367.2	12	141	115	390	385	60.1	FFB4	390	596	74.6	38k6	80
LS 132 M	216	250	178	367.2	12	141	115	390	-	-	FFB4	390	596	70.6	38k6	80
LSES 132 M	216	250	178	367.2	12	141	115	390	385	56.1	-	-	-	-	38k6	80
LSES 132 MU	216	250	178	367.2	12	141	115	390	412	70.7	FFB4	390	596	85.2	38k6	80

<sup>(1)</sup>Dimensions with potentiometer



<sup>(2)</sup>These values (the most binding) are given for information

## Dimensions of Commander ID300 system with or without FFB brake

IM B5 Flange form (IM 3001)

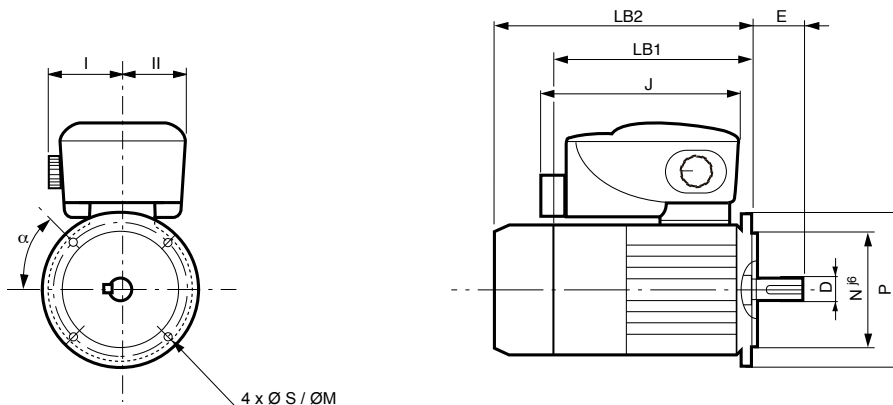
Dimensions in millimeters



Motor type	Smooth hole Flange form (Symb FF)													Output shaft		
	M	N	P	4xS	$\alpha^\circ$	I <sup>(1)</sup>	II	Motor Jmax <sup>(2)</sup>	Motor LB1	 kg <sup>(2)</sup>	Brake type	Brake Jmax <sup>(2)</sup>	Brake mot LB2	 kg <sup>(2)</sup>	D	E
LS 71 M	FF130	110	160	10	45	94	75	217	186	11.5	FFB1	277	286	14.5	14j6	30
LS 71 L	FF130	110	160	10	45	94	75	217	194	12.5	FFB1	277	296	15.5	14j6	30
LS 80 L	FF165	130	200	12	45	94	75	217	-	-	FFB1	277	312	18.1	19j6	40
LSES 80 LG	FF165	130	200	12	45	94	75	277	265	15.1	FFB1	277	409	22.2	19j6	40
LS 90 L	FF165	130	200	12	45	94	75	277	-	-	FFB2	277	409	22.4	19j6	40
LS 90 SL	FF165	130	200	12	45	94	75	277	-	-	FFB1, 2	277	409	29.1	24j6	50
LSES 90 SL	FF165	130	200	12	45	94	75	277	265	20.4	FFB1, 2	277	409	26.6	24j6	50
LSES 90 L	FF165	130	200	12	45	94	75	277	245	18	-	-	-	24j6	50	
LSES 90 LU	FF165	130	200	12	45	94	75	277	296	24.6	FFB2	390	409	30.8	24j6	50
LS 100 L	FF215	180	250	14.5	45	141	115	336	-	-	FFB2, 3	390	437	37.2	28j6	60
LSES 100 L	FF215	180	250	14.5	45	141	115	336	290	30.7	FFB2	390	437	36.9	28j6	60
LSES 100 LR	FF215	180	250	14.5	45	141	115	336	309	33.9	FFB2	390	437	40.1	28j6	60
LSES 100 LG	FF215	180	250	14.5	45	141	115	390	315	30.6	FFB2, 3	390	423	45.7	28j6	60
LS 112 MG	FF215	180	250	14.5	45	141	115	390	-	-	FFB3	390	448	37.7	28j6	60
LSES 112 MU	FF215	180	250	14.5	45	141	115	390	332	31.1	FFB3	390	448	49.1	28j6	60
LS 132 S	FF265	230	300	14.5	45	141	115	390	-	-	FFB3	390	490	52.7	38k6	80
LSES 132 SU	FF265	230	300	14.5	45	141	115	390	383	46.1	-	-	-	38k6	80	
LSES 132 SM	FF265	230	300	14.5	45	141	115	390	385	60.1	FFB4	390	596	74.6	38k6	80
LS 132 M	FF265	230	300	14.5	45	141	115	390	-	-	FFB4	390	596	70.6	38k6	80
LSES 132 M	FF265	230	300	14.5	45	141	115	390	385	56.1	-	-	-	38k6	80	
LSES 132 MU	FF265	230	300	14.5	45	141	115	390	412	70.7	FFB4	390	596	85.2	38k6	80

<sup>(1)</sup>Dimensions with potentiometer



<sup>(2)</sup>These values (the most binding) are given for information

## Dimensions of Commander ID300 system with or without FFB brake

IM B14 Flange form (IM 3601)

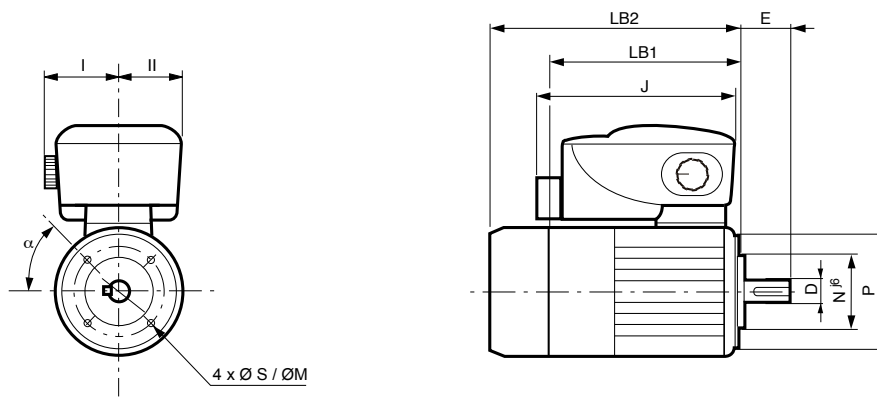
Dimensions in millimeters



Motor type	Tapped hole Flange form (Symb FF)														Output shaft	
	M	N	P	4xS	$\alpha^\circ$	I <sup>(1)</sup>	II	Motor J <sub>max</sub> <sup>(2)</sup>	Motor LB1	 kg <sup>(2)</sup>	Brake type	Brake J <sub>max</sub> <sup>(2)</sup>	Brake mot LB2	 kg <sup>(2)</sup>	D	E
LS 71 M	FT85	70	105	M6	45	94	75	217	186	11.5	FFB1	277	286	14.5	14j6	30
LS 71 L	FT85	70	105	M6	45	94	75	217	194	12.5	FFB1	277	296	15.5	14j6	30
LS 80 L	FT100	80	120	M6	45	94	75	217	-	-	FFB1	277	312	18.1	19j6	40
LSES 80 LG	FT100	80	120	M6	45	94	75	277	245	15.1	FFB1	277	389	22.2	19j6	40
LS 90 L	FT115	95	140	M8	45	94	75	277	-	-	FFB2	277	389	22.4	19j6	40
LS 90 SL	FT115	95	140	M8	45	94	75	277	-	-	FFB1, 2	277	389	29.1	24j6	50
LSES 90 SL	FT115	95	140	M8	45	94	75	277	245	20.4	FFB1, 2	277	389	26.6	24j6	50
LSES 90 L	FT115	95	140	M8	45	94	75	277	245	18	-	-	-	-	24j6	50
LSES 90 LU	FT115	95	140	M8	45	94	75	277	276	24.6	FFB2	390	389	30.8	24j6	50
LS 100 L	FT130	110	160	M8	45	141	115	336	-	-	FFB2, 3	390	437	37.2	28j6	60
LSES 100 L	FT130	110	160	M8	45	141	115	336	290	30.7	FFB2	390	437	36.9	28j6	60
LSES 100 LR	FT130	110	160	M8	45	141	115	336	309	33.9	FFB2	390	437	40.1	28j6	60
LSES 100 LG	FT130	110	160	M8	45	141	115	390	315	30.6	FFB2, 3	390	423	45.7	28j6	60
LS 112 MG	FT130	110	160	M8	45	141	115	390	-	-	FFB3	390	448	37.7	28j6	60
LSES 112 MU	FT130	110	160	M8	45	141	115	390	332	31.1	FFB3	390	448	49.1	28j6	60
LS 132 S	FT165	130	200	M10	45	141	115	390	-	-	FFB3	390	490	52.7	38k6	80
LSES 132 SU	FT165	130	200	M10	45	141	115	390	383	46.1	-	-	-	-	38k6	80
LSES 132 SM	FT165	130	200	M10	45	141	115	390	385	60.1	FFB4	390	596	74.6	38k6	80
LS 132 M	FT165	130	200	M10	45	141	115	390	-	-	FFB4	390	596	70.6	38k6	80
LSES 132 M	FT165	130	200	M10	45	141	115	390	385	56.1	-	-	-	-	38k6	80
LSES 132 MU	FT165	130	200	M10	45	141	115	390	412	70.7	FFB4	390	596	85.2	38k6	80

<sup>(1)</sup>Dimensions with potentiometer

<sup>(2)</sup>These values (the most binding) are given for information

## Selection of Commander ID300 system with gearboxes

Adapting the speed and torque to the machines driven is the role assigned to the gearboxes.

Leroy-Somer offers 3 ranges of helical gearboxes: Compabloc, Manubloc, Orthobloc, as well as a complete range with worm and wheel gears: Multibloc, offering a broad choice of possible implantations for every application.

Before selecting, you must know the following:

- gearbox implantation form (axial, parallel or orthogonal output)
- fixing form (feet, flange or pendular)
- gearbox technology (helical gear, conical torque, worm and wheel)
- drive shaft shape (solid, hollow, shrink disc)
- power of the motor and drive ( $P_n$  expressed in kW from 0.25 to 7.5)
- speed range at gearbox output (max  $N_s$  in rpm)

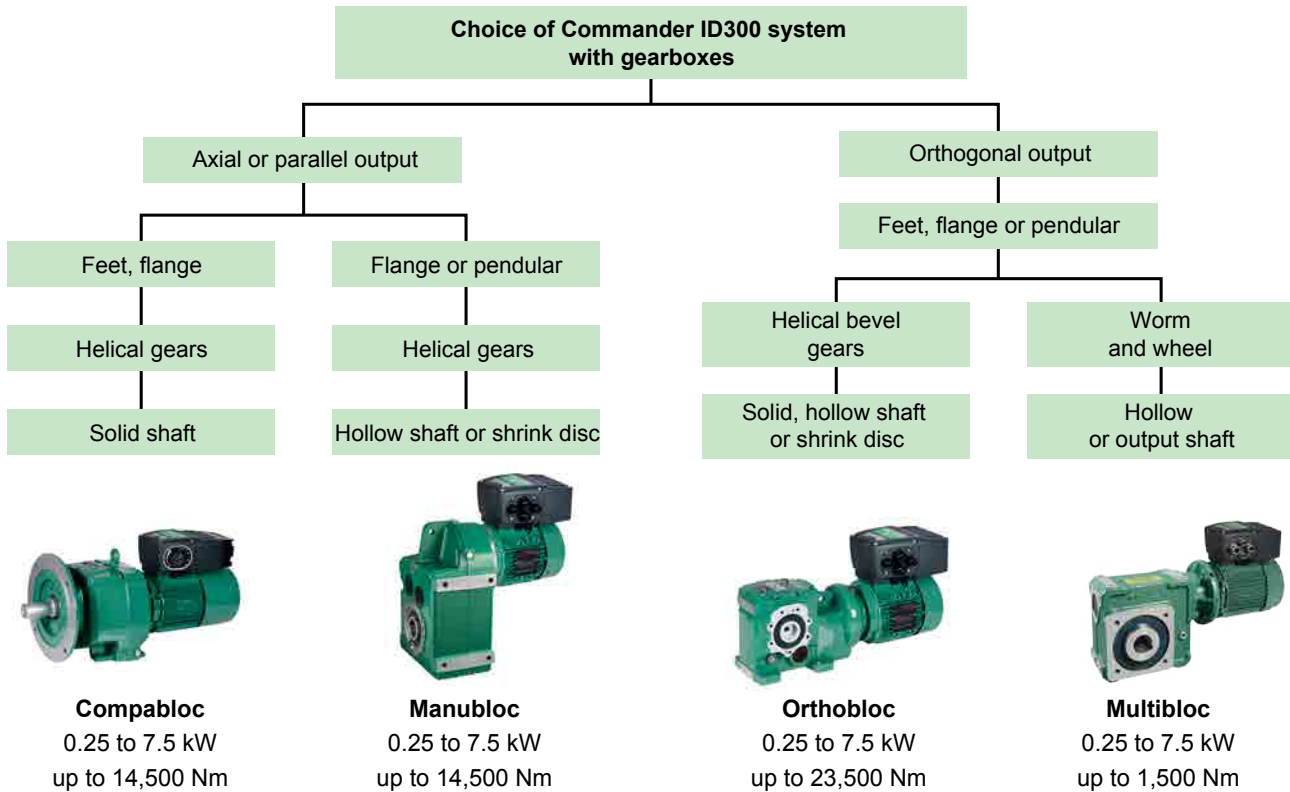

### Geared motor with or without brake: operation 10 to 80 Hz

The starting torque  $M_d$  guarantees the system from starting by meeting the low speed friction and efficiency constraints.

The maximum overload torque  $M_{MAX}$  can be used punctually to respond to a load variation (consecutive 60s maximum on an S1 cycle).

The rated torque available  $M_n$  (S1) varies according to the operating speed and reaches its maximum value between 10 and 50Hz.

The torque  $M_n$  (S1) then decreases over the 50 to 80Hz zone.

The available torque  $M_{MIN}$  (S1) over the entire speed range (10 to 80 Hz) is defined at the highest operating speed (motor at 80 Hz - 2400 min<sup>-1</sup>). For applications with geared motors, sizing this system based on this torque guarantees operation over the entire speed range, as well as an increased start-up torque (adaptation of the reduction ratio to the gearbox).

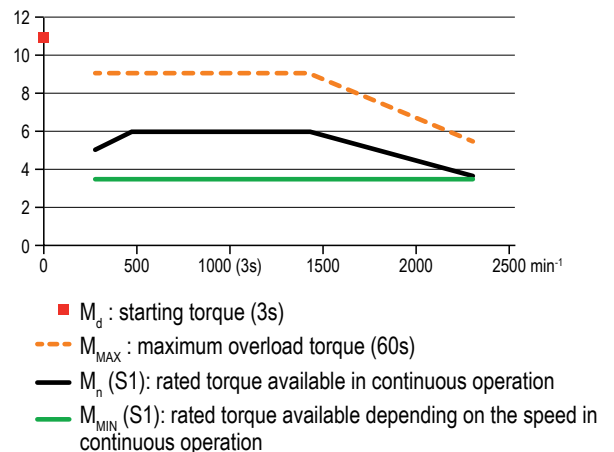



## Typical designation of gearboxes

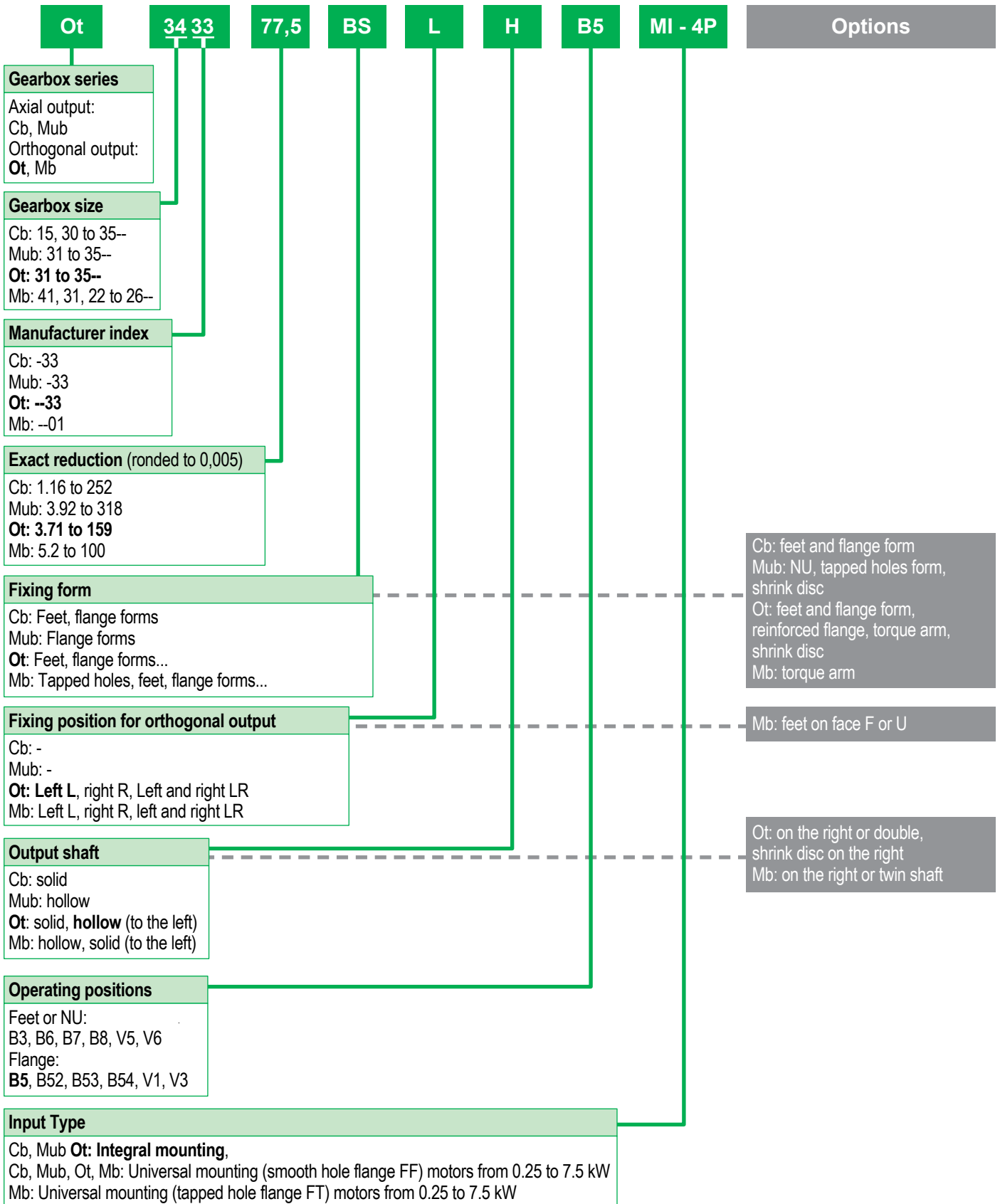

## Simplified table selection of the system with Compabloc, with or without brake

### Compabloc gearbox

Kp factor  $\geq 1$



Compabloc geared motor - 4P IMfinity® motor: 0.25 to 7.5 kW Commander ID300/302: 230V 1 ph / 3 ph and 400V 3 ph - 50 Hz power supply																
4 poles 1500 min <sup>-1</sup>		P <sub>n</sub> (kW)	0.25	0.37	0.55	0.75	0.9	1.1	1.5	1.8	2.2	3	4	5.5	7.5	
			IE3	71 M	71 M	71 L	80 LG		90 SL	90 LU	100 L	100 LR	100 LG	112 MU	132 SM	132 MU
		I <sub>a</sub>	IE2	71 M	71 M	71 L	80 LG		90 SL	90 L	90 LU	100 L	100 LR	112 MU	132 SU	132 M
N <sub>s</sub> mini	N <sub>s</sub> maxi		230V - 1ph ; 230V - 3ph ; 400V - 3 ph						230V - 3 ph ; 400V - 3 ph				400V - 3 ph			
3.00	24.0	100														
3.33	26.7	90														
3.75	30.0	80														
4.23	33.8	71														
4.76	38.1	63	Cb 3033										Cb 34	Cb 35		
5.36	42.9	56														
6.00	48.0	50														
6.67	53.3	45														
7.50	60.0	40	Cb 1503													
8.45	67.6	35.5														
9.52	76.2	31.5														
10.7	85.7	28														
12.0	96.0	25														
13.4	107	22.4														
15.0	120	20														
16.7	133	18	Cb 1502													
18.8	150	16														
21.4	171	14														
24.0	192	12.5														
26.8	214	11.2														
30.0	240	10														Cb 32
Brake Motor	P <sub>n</sub> (kW)		0.25	0.37	0.55	0.75	0.9	1.1	1.5	1.8	2.2	3	4	5.5	7.5	
FFB NIE			71 M FFB1	71 L FFB1	80 L FFB1	90 SL FFB2	90 L FFB2	100 L FFB2	100L FFB3	112 MG FFB3	132 S FFB3	132 M FFB4				
FFB IE3			71 M FFB1	71 L FFB1	80 LG FFB1	90 SL FFB2	90 LU FFB2	100 L FFB2	100 LR FFB2	100 LG FFB3	112 MU FFB3	132 SM FFB4	132 MU FFB4			

Please note FFB brake is not available with 220 V supply

## Dimensions of Compabloc gearbox

### Compabloc gearbox

Standard position: gearbox seen from side F, motor to the rear, feet at the ground

Dimensions in millimeters

#### Feet form

(See motor dimensions P22)

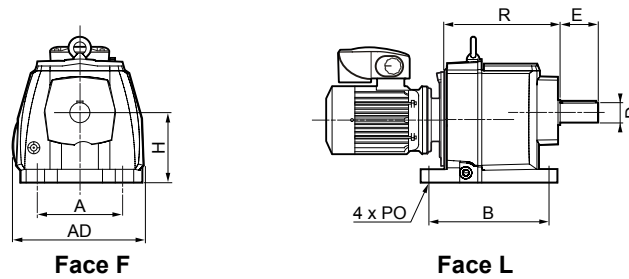

Cb type	S Feet Form						S solid shaft		kg <sup>1</sup>
	A	AD	B	H	4xPO	R	ØD	E	
Cb 35	280	360	280	225	22	290	60m6	120	90
Cb 34	230	305	235	180	18	251	50k6	100	50
Cb 33	170	257	240	140	18	224.5	40k6	80	30
Cb 32	135	222	192	115	14	182.5	30j6	60	18.5
Cb 31	110	172	165	90	9	165.5	25j6	50	13
Cb 30	125	150	105/125	75	9	127	20j6	40	4.9
Cb 15	100	120	105	90	7	117	16j6	40	3.2

<sup>1</sup>: for information

#### Flange form

(See motor dimensions P22)

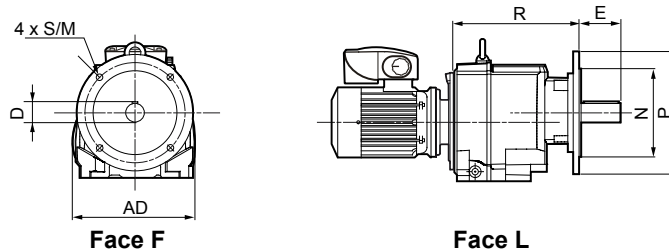

Cb type	BS flange form						S solid shaft		kg <sup>1</sup>
	AD	M	Nj6	P	R	4xS	ØD	E	
Cb 35	360	350	300	400	315	18	60m6	120	97
Cb 34	305	300	250	350	270	18	50k6	100	56
Cb 33	257	265	230	300	250.5	14	40k6	80	34
Cb 32	222	215	180	250	192.5	14	30j6	60	18.8
Cb 31	172	165	130	200	173.5	12	25j6	50	13.4
Cb 30	140	115	95	140	127	9	20j6	40	4.9
Cb 15	118	100	80	120	117	7	16j6	40	2.9

Cb type	BD1 flange form						S solid shaft		kg <sup>1</sup>
	AD	M	Nj6	P	R	4xS	ØD	E	
Cb 35	360	300	250	350	315	18	60m6	120	96
Cb 34	305	265	230	300	270	14	50k6	100	55
Cb 33	257	215	180	250	250.5	14	40k6	80	33
Cb 32	222	165	130	200	192.5	12	30j6	60	18.7
Cb 31	172	130	110	160	173.5	9	25j6	50	13.3
Cb 30	140	100	80	120	127	7	20j6	40	4.8
Cb 15	118	85	70	105	117	7	16j6	40	2.8

Cb type	BD2 flange form						S solid shaft		kg <sup>1</sup>
	AD	M	Nj6	P	R	4xS	ØD	E	
Cb 35	360	265	230	300	315	14	60m6	120	90
Cb 34	305	215	180	250	270	14	50k6	100	54
Cb 33	257	165	130	200	250.5	11	40k6	80	32.5
Cb 32	222	130	110	160	192.5	9	30j6	60	18.6
Cb 31	172	115	95	140	173.5	9	25j6	50	13.2
Cb 30	140	130	110	160	127	9	20j6	40	5
Cb 15	118	115	95	140	117	9	16j6	40	3

Cb type	BD3 flange form						S solid shaft		kg <sup>1</sup>
	AD	M	Nj6	P	R	4xS	ØD	E	
Cb 31	172	100	80	120	173.5	7	25j6	50	13.1
Cb 30	140	165	130	200	127	12	20j6	40	5.1

<sup>1</sup>: for information

## Simplified table selection of the system with Manubloc, with or without brake

### Manubloc gearbox

Kp factor  $\geq 1$



**Manubloc geared motor- 4P IMfinity® motor: 0.25 to 7.5 kW**  
**Commander ID300/302: 230V 1 ph / 3 ph and 400V 3 ph - 50 Hz power supply**

4 poles 1500 min <sup>-1</sup>		P <sub>n</sub> (kW)	0.25	0.37	0.55	0.75	0.9	1.1	1.5	1.8	2.2	3	4	5.5	7.5		
			IE3	71 M	71 M	71 L	80 LG		90 SL	90 LU	100 L	100 LR	100 LG	112 MU	132 SM	132 MU	
		IE2	71 M	71 M	71 L	80 LG		90 SL	90 L	90 LU	100 L	100 LR	112 MU	132 SU	132 M		
N <sub>s</sub> min	N <sub>s</sub> max	la	230V - 1ph; 230V - 3ph; 400V - 3ph						230V - 3 ph; 400V - 3 ph				400V - 3 ph				
3.00	24.0	100															
3.33	26.7	90															
3.75	30.0	80															
4.23	33.8	71															
4.76	38.1	63															
5.36	42.9	56															
6.00	48.0	50															
6.67	53.3	45															
7.50	60.0	40															
8.45	67.6	35.5															
9.52	76.2	31.5															
10.7	85.7	28															
12.0	96.0	25															
13.4	107	22.4															
15.0	120	20															
16.7	133	18															
18.8	150	16															
21.4	171	14															
24.0	192	12.5															
26.8	214	11.2															
30.0	240	10															
Brake Motor	P <sub>n</sub> (kW)	0.25	0.37	0.55	0.75	0.9	1.1	1.5	1.8	2.2	3	4	5.5	7.5			
FFB NIE		71 M FFB1	71 L FFB1	80 L FFB1		90 SL FFB2	90 L FFB2	100 L FFB2	100L FFB3	112 MG FFB3	132 S FFB3	132 M FFB4					
FFB IE3		71 M FFB1	71 L FFB1	80 LG FFB1		90 SL FFB2	90 LU FFB2	100 L FFB2	100 LR FFB2	100 LG FFB3	112 MU FFB3	132 SM FFB4	132 MU FFB4				

Please note FFB brake is not available with 220 V supply



## Dimensions of Manubloc gearbox

### Manubloc gearbox

Standard position: gearbox seen from side F, motor to the rear, side D facing the ground

Dimensions in millimeters

**BT flange form**  
**H hollow shaft**  
 (See motor  
 dimensions P22)

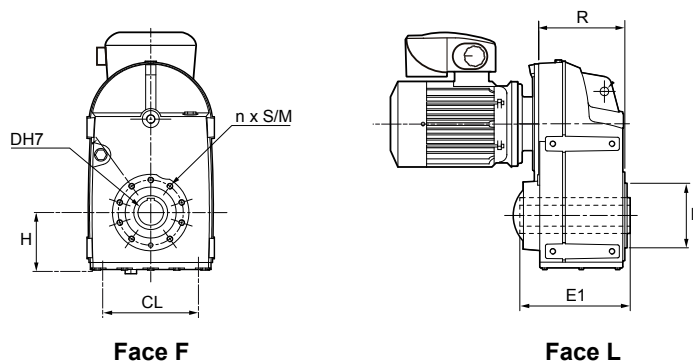

Mub type	BT flange form						H hollow shaft		kg <sup>1</sup>
	CL	H	M	Nj6	R	nxS	ØDH7	E1	
Mub 35	355	171	215	180	236	6xM12x20	60	292	115
Mub 34	282	126	180	160	209.5	6xM12x22	50	260	69
Mub 33	269	127	165	130	159	6xM10x18	40	191.5	43
Mub 32	199	94.5	215	110	150	4xM8x12	30	190.5	26
Mub 31	191	95	115	95	117.5	4xM8x12	30	182	15.5

<sup>1</sup>: for information

**BS, BD1 flange form**  
**H hollow shaft**  
 (See motor  
 dimensions P22)

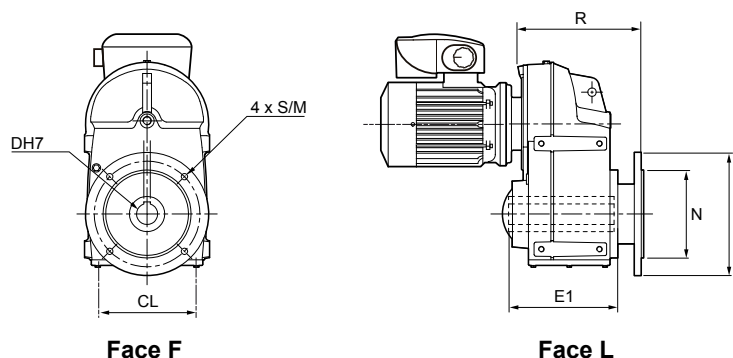

Mub type	BS flange form						H hollow shaft		kg <sup>1</sup>
	CL	M	Nj6	P	R	4xS	ØDH7	E1	
Mub 35	355	300	250	350	323	18	60	292	130
Mub 34	282	265	230	300	254.5	14	50	260	79
Mub 33	269	265	230	300	204	14	40	191.5	51
Mub 32	199	215	180	250	185	14	30	190.5	31

Mub type	BD1 flange form						H hollow shaft		kg <sup>1</sup>
	CL	M	N	P	R	4xS	ØDH7	E1	
Mub 34	282	215	180	250	275.5	14	50	260	78
Mub 33	269	215	180	250	225	14	40	191.5	50
Mub 32	199	165	130	200	208	12	30	190.5	30

<sup>1</sup>: for information

## Simplified table selection of the system with Orthobloc, with or without brake

### Orthobloc gearbox

Kp factor  $\geq 1$



**Orthobloc geared motor - 4P IMfinity® motor: 0.25 to 7.5 kW**  
**Commander ID300/302: 230V 1 ph / 3 ph and 400V 3 ph - 50 Hz power supply**

**4 poles**  
**1500 min<sup>-1</sup>**

N <sub>s</sub> min	N <sub>s</sub> max	I <sub>a</sub>	P <sub>n</sub> (kW)																						
			0.25	0.37	0.55	0.75	0.9	1.1	1.5	1.8	2.2	3	4	5.5	7.5										
		IE3		71 M		71 L		80 LG		90 SL		90 LU		100 L		100 LR		100 LG		112 MU		132 SM		132 MU	
		IE2		71 M		71 L		80 LG		90 SL		90 L		90 LU		100 L		100 LR		112 MU		132 SU		132 M	
			230V - 1ph; 230V - 3ph; 400V - 3 ph							230V - 3 ph; 400V - 3 ph							400V - 3 ph								
3.0	24.0	100																							
3.3	26.7	90																							
3.8	30.0	80																							
4.2	33.8	71																							
4.8	38.1	63																							
5.4	42.9	56																							
6.0	48.0	50																							
6.7	53.3	45																							
7.5	60.0	40																							
8.5	67.6	35.5																							
9.5	76.2	31.5																							
10.7	85.7	28																							
12.0	96.0	25																							
13.4	107	22.4																							
15.0	120	20																							
16.7	133	18																							
18.8	150	16																							
21.4	171	14																							
24.0	192	12.5																							
26.8	214	11.2																							
30.0	240	10																							
Brake Motor	P <sub>n</sub> (kW)	0.25	0.37	0.55	0.75	0.9	1.1	1.5	1.8	2.2	3	4	5.5	7.5											
FFB NIE		71 M FFB1	71 L FFB1	80 L FFB1	90 SL FFB2	90 L FFB2	100 L FFB2	100L FFB3	112 MG FFB3	132 S FFB3	132 M FFB4														
FFB IE3		71 M FFB1	71 L FFB1	80 LG FFB1	90 SL FFB2	90 LU FFB2	100 L FFB2	100 LR FFB2	100 LG FFB3	112 MU FFB3	132 SM FFB4	132 MU FFB4													

Please note FFB brake is not available with 220 V supply

## Orthobloc gearbox

Standard position: gearbox seen from side F, motor to the rear, side D facing the ground

### S feet form

#### Output shaft

(See motor dimensions P22)

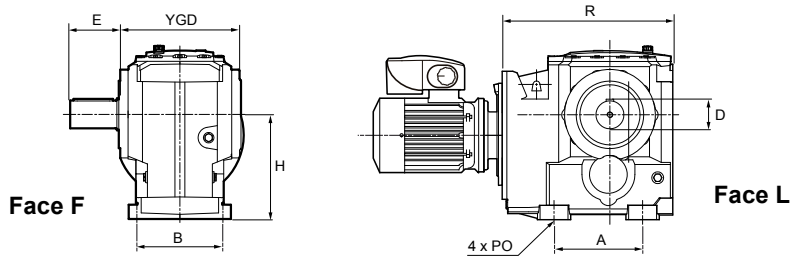

Ot type	S Feet Form						Output shaft L <sup>1</sup>		kg <sup>2</sup>
	A	B	H	4xPO	R max	YGD	ØD	E	
Ot 35	230	180	212	22	405	225	60m6	120	83
Ot 34	190	165	180	18	350	207	50k6	100	60
Ot 33	150	140	140	14	305	170	40k6	80	38
Ot 32	150	120	112	11	290	145	30j6	60	22
Ot 31	100	100	80	9	245	120	25j6	50	14.5

<sup>1</sup> right output identical: R

<sup>2</sup> for information

### S, BTLR feet and flange form

#### Hollow shaft

(See motor dimensions P22)

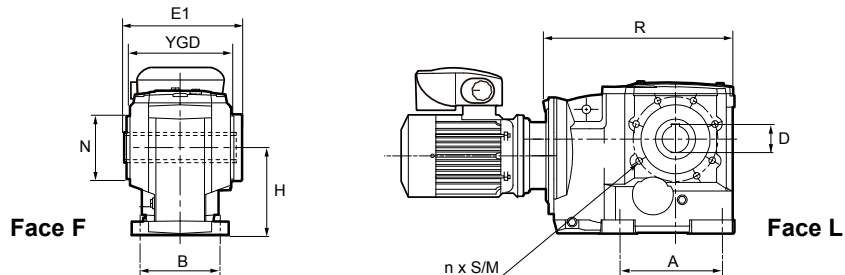

Ot type	SBTLR Feet and Flange Form							H hollow shaft		kg <sup>2</sup>	
	A	B	H	M	N	R max	nxS	YGD	ØDH7		E1
Ot 35	230	180	212	190	155j6	405	6xM16x27	225	60	244	82
Ot 34	190	165	180	152	130j6	350	6xM12x22	207	50	226	59.5
Ot 33	150	140	140	123	100k6	305	6xM12x22	170	40	173	37
Ot 32	150	120	112	100	80k6	290	6xM10x22	145	35	151	21.8
Ot 31	100	100	80	95	85j6	245	4xM8x12	120	30	130	14

<sup>2</sup> for information

### Flange form BSL (or BSR<sup>1</sup>), BDL (or BDR<sup>1</sup>)

#### Output shaft

(See motor dimensions P22)

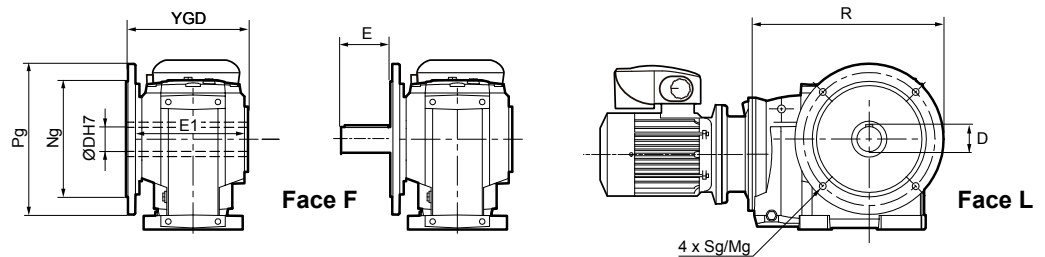

Ot type	BSL Flange Form (or BSR <sup>1</sup> )					H hollow shaft		Output shaft L <sup>1</sup>		kg <sup>2</sup>	
	4xSg	Mg	Ng	Pg	R max	YGD	ØDH7	E1	ØD		E
Ot 35	18	350	300j6	400	473	259	60	244	60m6	120	94
Ot 34	18	300	250j6	350	411	235	50	226	50k6	100	68
Ot 33	14	265	230j6	300	365	208	40	173	40k6	80	42
Ot 32	12	215	180j6	250	322	175	35	151	30j6	60	23.3
Ot 31	9	130	110j6	165	247.5	149	30	130	25j6	50	14.8

<sup>1</sup> right output identical: 4xSd/Md Nd Pd, shaft R

<sup>2</sup> for information

Ot type	BDL Flange Form (or BDR <sup>1</sup> )					H hollow shaft		Output shaft L <sup>1</sup>		kg <sup>2</sup>	
	4xSg	Mg	Ng	Pg	R max	YGD	ØDH7	E1	ØD		E
Ot 35	18	300	250j6	350	448	259	60	244	60m6	120	93
Ot 34	14	265	230j6	300	386	235	50	226	50k6	100	67
Ot 33	14	215	180j6	250	340	208	40	173	40k6	80	42
Ot 32	12	165	130j6	200	297	175	35	151	30j6	60	23

<sup>1</sup> right output identical: 4xSd/Md Nd Pd, shaft R

<sup>2</sup> for information

## Simplified table selection of the system with multibloc, with or without brake

### Multibloc gearbox

Kp factor  $\geq 1$



Multibloc geared motor - 4P IMfinity® motor: 0.25 to 7.5 kW Commander ID300/302: 230V 1 ph / 3 ph and 400V 3 ph - 50 Hz power supply														
		0.25	0.37	0.55	0.75	0.9	1.1	1.5	1.8	2.2	3	4	5.5	7.5
		71 M	71 M	71 L	80 LG		90 SL	90 LU	100 L	100 LR	100 LG	112 MU	132 SM	132 MU
		71 M	71 M	71 L	80 LG		90 SL	90 L	90 LU	100 L	100 LR	112 MU	132 SU	132 M
		230V - 1ph; 230V - 3ph						230V - 3 ph; 400V - 3 ph				400V - 3 ph		
N <sub>s</sub> min	N <sub>s</sub> max	I <sub>a</sub>	4 poles 1500 min <sup>-1</sup>											
			3.00	24.0	100									
3.75	30.0	80		Mb 22			Mb 24							
5.00	40.0	60										Mb 26		
6.00	48.0	50												
7.50	60.0	40									Mb 25			
10.0	80.0	30												
12.0	96.0	25		Mb 41	Mb 31			Mb 23		Mb 24				
15.0	120	20												
20.0	160	15					Mb 22							
24.0	192	12.5												
30.0	240	10											Mb 24	
40.0	320	7.5		Mb 41										Mb 25
60.0	480	5												
Brake Motor	P <sub>n</sub> (kW)	0.25	0.37	0.55	0.75	0.9	1.1	1.5	1.8	2.2	3	4	5.5	7.5
FFB NIE		71 M FFB1	71 L FFB1	80 L FFB1	90 SL FFB2	90 L FFB2	100 L FFB2	100 LR FFB2	100 LG FFB3	112 MG FFB3	132 S FFB3	132 M FFB4		
FFB IE3		71 M FFB1	71 L FFB1	80 LG FFB1	90 SL FFB2	90 LU FFB2	100 L FFB2	100 LR FFB2	100 LG FFB3	112 MU FFB3	132 SM FFB4	132 MU FFB4		

Please note FFB brake is not available with 220 V supply



# Dimensions Multibloc gearbox

Dimensions in millimeters

## Multibloc gearbox

Standard position: gearbox seen from side F, motor to the rear, side D facing the ground

### NU form

#### Hollow shaft

(See motor dimensions P22,23)

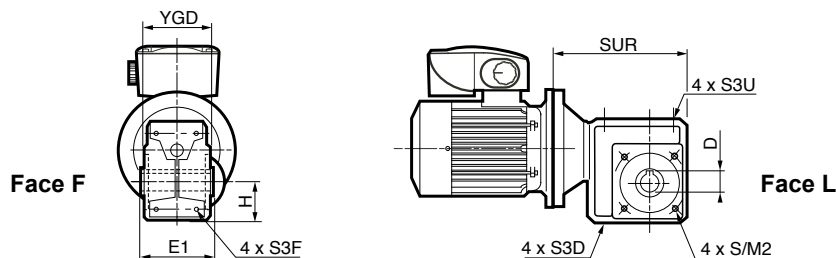

Mb type	NU form								H hollow shaft		kg <sup>2</sup>
	H	M2	4xS	SUR max	4xS3D	4xS3F	4xS3U	YGD	ØD	E1	
Mb 26	100	1	-	319	M14x20	M14x20	M14x20	174	50H7	188	41
Mb 25	90	180	M12x20	275	M12x20	M12x20	M12x20	156	45H7	168	33
Mb 24	75	130	M10x15	240	M10x15	M10x15	M10x15	128	35H7	138	20
Mb 23	63	115	M8x12	198	M8x12	M8x12	M8x12	108	30H7	118	12
Mb 22	56	105	M8x12	173	M8x12	M8x12	M8x12	98	25H7	108	4
Mb 31	50	85	M8x12	120	M8x12	M8x12*	-	82	20H7	90	5
Mb 41	50	85	M6x13	120	6.5	6.5	6.5	78	20H8	78	2.2

<sup>1</sup> Mb 26 BT form: M2 = 165 (44kg)

<sup>2</sup> for information

### NSD feet form

#### Output shaft

(See motor dimensions P22,23)

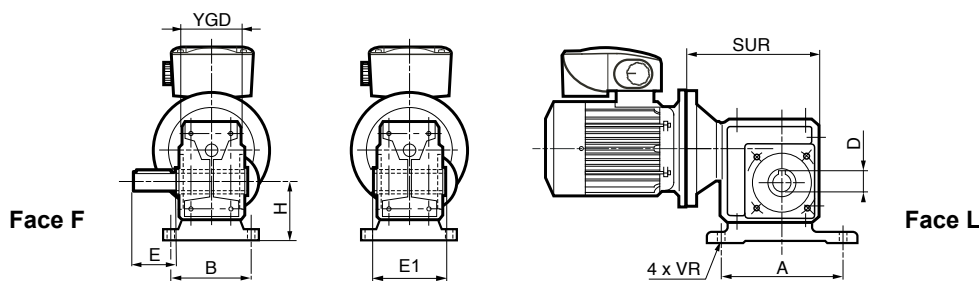

Mb type	NSD feet form*						H hollow shaft		Output shaft HL <sup>1</sup>		kg <sup>2</sup>
	A	B	H	SUR max	4xVR	YGD	ØD	E1	ØD	E	
Mb 26	250	180	125	319	18	174	50H7	188	50h6	100	49.1
Mb 25	220	156	112	275	16	156	45H7	168	45h6	90	39.5
Mb 24	202	156	90	240	14	128	35H7	138	35h6	70	22
Mb 23	154	128	80	198	11	108	30H7	118	30h6	60	13.5
Mb 22	134	125	71	173	11	98	25H7	108	25h6	50	10
Mb 31/41	-	-	-	-	-	-	-	-	-	-	-

<sup>1</sup> right output identical: HR

\* NSF, NSU, feet form

<sup>2</sup> for information

### Flange form BS L<sup>1</sup>

#### Output shaft

(See motor dimensions P22,23)

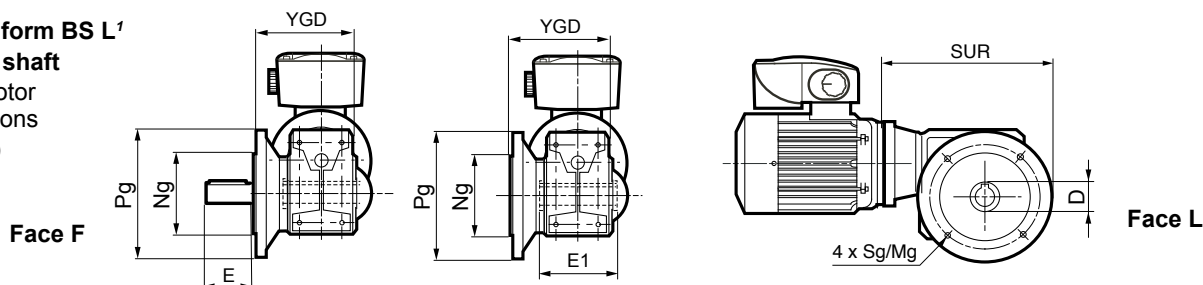

Mb type	Flange form BS L <sup>1</sup>						H hollow shaft		kg <sup>2</sup>
	Mg	Ng	Pg	SUR max	4xSg	YGD	ØD	E	
Mb 26	300	250/6	350	394	18	240	50H7	188	56
Mb 25	265	230/6	300	335	14	204	45H7	168	44
Mb 24	215	180/6	250	290	14	190	35H7	138	27.3
Mb 23	165	130/6	200	235	11	160	30H7	118	16.2
Mb 22	165	130/6	200	217	11	149.5	25H7	108	12.9
Mb 31 <sup>2</sup>	100	-	120	135	7	118	20H7	90	6.5
Mb 41	100	80/6	120	129	7	118	20H8	78	3

Mb type	Flange form BD L <sup>1</sup>						Output shaft HL		kg <sup>2</sup>
	Mg	Ng	Pg	SUR max	4xSg	YGD	ØD	E	
Mb 26	265	230/6	300	369	14	235	50h6	100	57
Mb 25	215	180/6	250	310	14	216	45h6	90	43
Mb 24	165	130/6	200	265	11	190	35h6	70	26.5
Mb 23	130	110/6	160	215	9	160	30h6	60	15.2
Mb 22	130	110/6	160	197	9	149.5	25h6	50	11.9
Mb 31 <sup>2</sup>	85/115	-	105/140	127.5/145	7/9	117/120	20h6	40	6.2
Mb 41	85/115	70/6/95/6	105/140	121.5/139	7/9	118/118	20/6	40	6

<sup>1</sup> Right output identical: BD R, HR shaft

<sup>2</sup> for information

<sup>3</sup> Mb 31 Flange BN L (Ø85, 100 with radial ports)

# Commander ID300

## Make it your own

We have developed different tools and manuals to support you from pre selection of your system, commission to after sales support.



Installation and quick start commissioning guide containing all the required information to easily install and setup your system



26 languages dedicated guide providing you general recommendations for storing and installing.

For more information, please visit [www.commanderID300.info](http://www.commanderID300.info)

## Configurator

Configurator is a powerful tool to assist you in the selection of motors or geared motors combined with variable speed drives. Continuous evolution of this software reaches a new level with IMfinity® motors and geared motors, giving the user the possibility to link-up the motor and drive selection.

Best-in-class motors, geared motors and drives combined with this advanced tool ensure the best association is made when selecting products.

To verify if your country is covered by the Express Availability offer or by the 24H Express transport, please contact your local Automation Center.



Environment selection

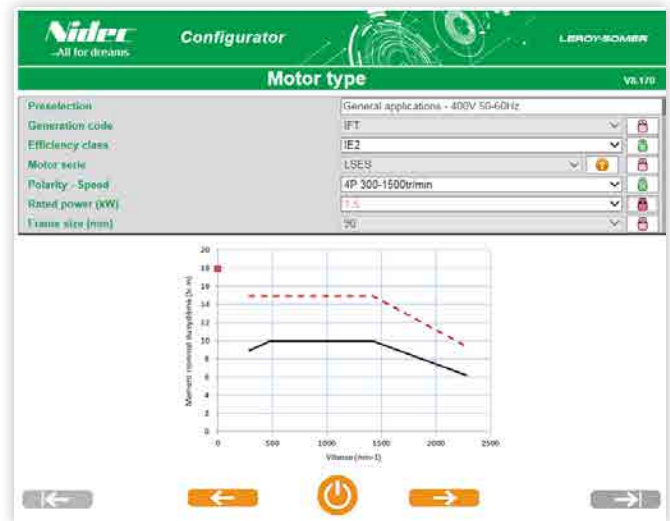

Drive & motor selection

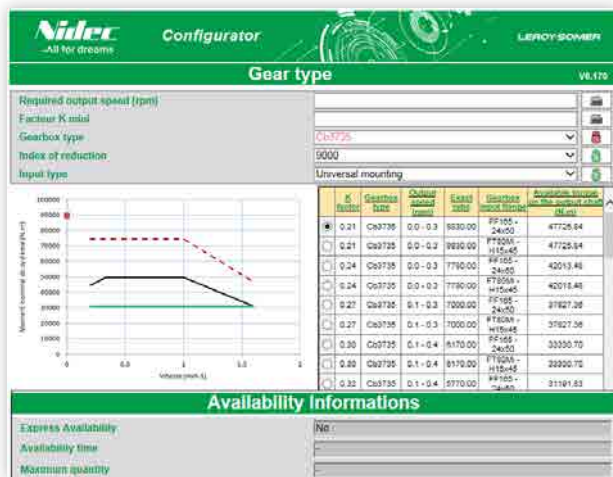

Gearbox selection, linked to motor selection

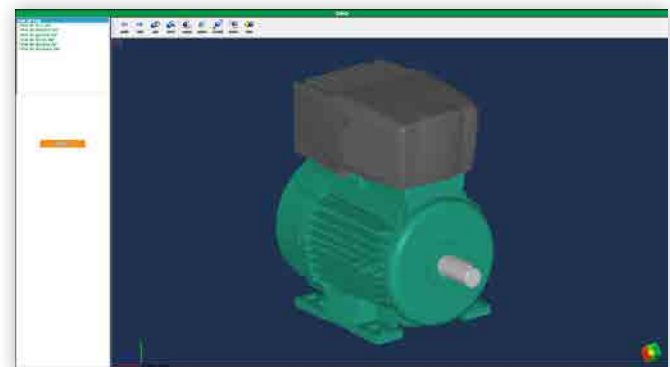

CAD files for motors (2D, 3D)

**LEROY-SOMER**<sup>™</sup>

[www.leroy-somer.com](http://www.leroy-somer.com)

**Connect with us at:**

[twitter.com/Leroy\\_Somer](https://twitter.com/Leroy_Somer)

[facebook.com/leroy-somer.nidec](https://facebook.com/leroy-somer.nidec)

[youtube.com/user/LeroySomerOfficiel](https://youtube.com/user/LeroySomerOfficiel)



**Nidec**  
All for dreams

© 2017 Moteurs Leroy-Somer SAS. The information contained in this brochure is for guidance only and does not form part of any contract. The accuracy cannot be guaranteed as Moteurs Leroy-Somer SAS have an ongoing process of development and reserve the right to change the specification of their products without notice.

Moteurs Leroy-Somer SAS. Headquarters: Bd Marcellin Leroy, CS 10015, 16915 Angoulême Cedex 9, France. Share Capital: 65 800 512 €, RCS Angoulême 338 567 258.